

User

MUCOLD

Verification Unit cooler

15.07.2020

Air inlet temperature	°C	0	Evaporating temperature	°C	-8,0
TD	°C	8,0	Refrigerant		R404A
Min number of units in room		1			

Heat exchanger	Standard	Casing	Standard
Motorfans feed	230/1/50-60	Fan motors	Standard
Defrost	Electric		

Selected model: 1 x EVS 181 ED

Capacity	kW	1,695			
TD	°C	8,0	Tot. air flow	m3/h	870

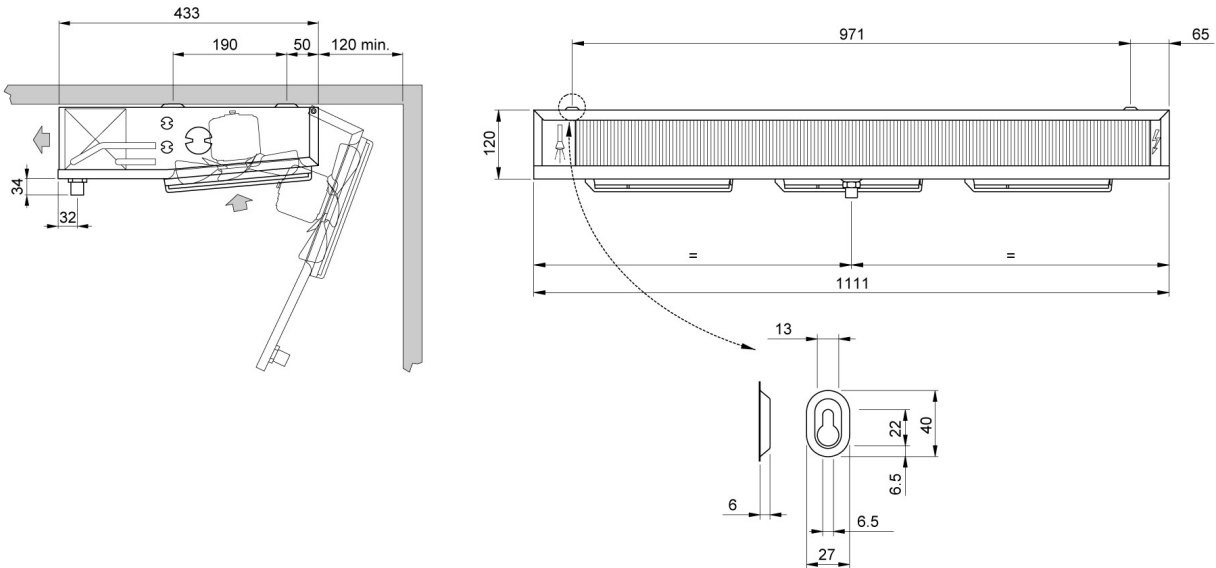

Weight	kg	10,500			
Internal surface	m2	0,75	External surface	m2	5,30
Input connection		1/2" SAE	Output connection		16 mm
Total circuit capacity	dm3	1,07	Fin spacing	mm	3.5 / 7
Drain connection		1/2" GAS			
Defrost	ED	Electric		Watt	1080
Fan	n.	3	Diameter	mm	200
Air flow	m3/h	870	Air throw	m	4,5
Feed	V	230/1/50-60	Fan speed	rpm	1300
Fan	A	1,05	Total power	Watt	159
Tot. Pres.S.Lev. 10 m.	dB(A)	37			

N.B.: we shall not be liable for the performances and the quality of sold products, if fitted or connected to fan motor speed regulation or control systems that are different from the ones proposed or installed by us.